

Document No:

## PRODUCT SPECIFICATION

HN-LB-RX

ISSUED TO		
Revision#	1.0	
DATE ISSUED	November. 13, 2006	
Approval Check Items		
Draft	Checked	Approved
Celia		

Document No:

## Description

The platform is based on state-of-the-art RF-to-fiber technology. The L band RX module is designed to meet increasing demands for higher performance and more RF control and monitoring. This module can compatible with other modules of ATC headend product series to integrate into the same chassis. The module contains a high performance, advanced circuitry achieves, and ideal for satellite applications. All configuration parameters of modules can be monitored via HN-SMM equipment management module

## Features

- Hot-swap capability
- Bandwidth 950~2150MHz
- Automatic/manual gain control (AGC/MGC)
- RF output test point
- Front panel LEDs indication
- Low power consumption
- Local and remote software for status monitoring

## Specifications

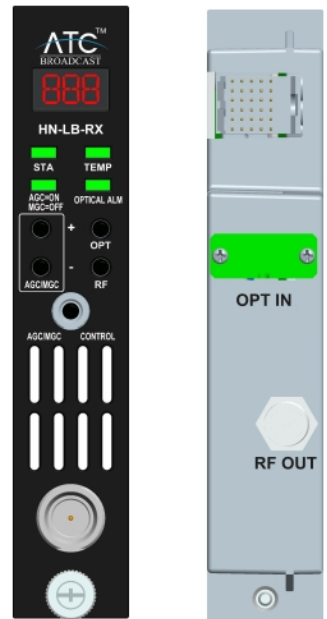

Parameter	Unit	Specification	Note
<b>Optical Performance</b>			
Wavelength	nm	1270~1610	--
Optic power	dBm	-14~3	--
Optic connector	--	SC/APC	--
<b>RF Performance</b>			
Bandwidth	MHz	950-2150	--
Return loss	-dB	≥10	--
Impedance	ohm	75	--
Flatness	dB	+/-1.75 ± 0.25 dB in any 36 MHz	--
OUtput Power	dBm	-40~-20	--
Connector	--	F-female	--
Test point	dB	-20+/-2	--
CNR	dB	52	1
IMD	dB	≥40	1

Document No:

Electrical/Physical Performance			
Supply voltage	VDC	24	--
Power consumption	W	<7	--
Dimensions	mm	400D x 24W x 128H	--
Weight	Kg	1.2	--
Operation temperature	°C	0~50	--
Storage temperature	°C	-40~70	--
Relative humidity	%	5~85	--

Notes:

- Two tone frequency test 2 GHz&2.008 GHz.

### Block Diagram

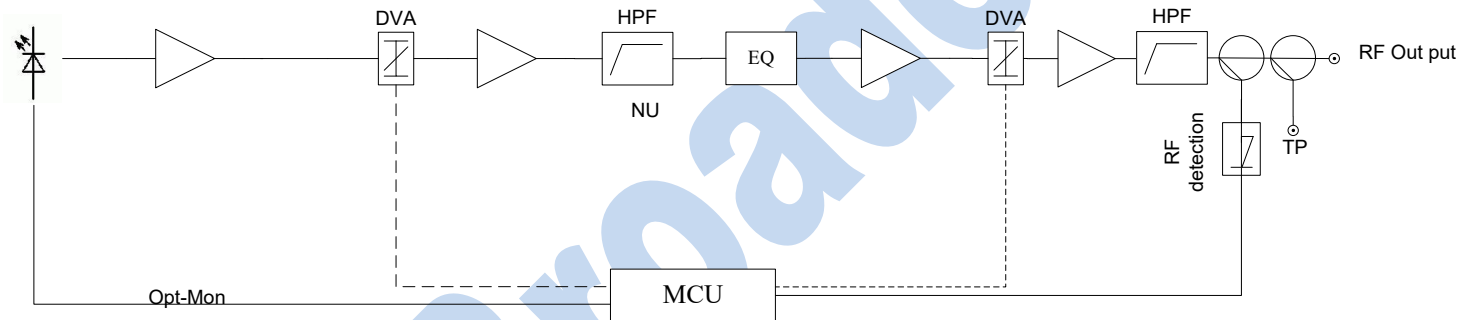

### Dimensions (mm)

